

NUMERICAL SOLVING PROBLEMS OF SPACECRAFT DESIGN

Aksenov A.A. *, Dyadkin A.A. **, Rybak S.P. **, Simakova T.V. **
*** TESIS Ltd, Moscow, Russia, ** JSV «RSC Energia» Korolev, Russia**

Keywords: *CFD, numerical simulation, spacecraft, design*

Abstract

Two different complex problems arising during spacecraft design are discussed in this paper. One problem is a definition of impulse for a safety separation of a parachute container lid. Another problem is defining a shock-wave interaction on the spacecraft at turning on emergency rescue system. Both problem are very hard and expensive for solving by experimental methods, and RSC Energia gets here all benefits of numerical simulation by using CFD code FlowVision.

1 Introduction

Application of the numerical modeling using supercomputer technology is an important factor now to win the technological advantage, shortening the design phase, reducing the risks, as well as reduce the cost of design and production. RSC "Energia" is actively used this approach to develop a new reusable spacecraft returned (Fig. 1). CFD code FlowVision is used by "Energia" for solving different aerodynamic problems rising during developing this project. CFD code FlowVision simulates three-dimensional liquid of gas motion at arbitrary Mach numbers. It was originally developed for the aerospace industry. It has the following features that make it most effective to study the aerodynamics of spacecraft in the design process: a fully automatic mesh generator. The mesh has local dynamic adaptation. The adaptation refines mesh in regions of high solution gradients or near complex spacecraft shape. FlowVision simulates also the gas flow around bodies moving relative stationary boundaries with the ability of collision.

FlowVision is finite volume CFD code with implicit method of solving fluid motion equation.

The solution of several problems appeared at different stages of spacecraft design is described in this paper using numerical simulation. The separation of a parachute container lid (PCL) before returnable apparatus (RA) landing, the definition of shock-wave impacts on the hull of the ship when triggered emergency rescue system (ERS) in the case in the derivation are describe in this paper.

2 The separation of a parachute container lid

Experimental investigating this problem is almost impossible, because of requires a significant time and financial resources. Moreover, results can be obtained in a limited range of initial parameters: attack angle of spacecraft, value of shooting impulse of the lid, spacecraft speed.

Much more fruitful approach is using CFD. The problem of determining the aerodynamic characteristics of the reusable vehicle and PCL solved in the coordinate system associated with the center of mass of spacecraft, so it is stationary in the computational domain. To simulate the PCL motion with six degrees of freedom used FlowVision technology of the moving body in stationary computational domain [1]. A computational mesh is adapted around the spacecraft and around the lid (Fig. 2). The adaptation volume follows the lid to

supply its motion in refine mesh for accurate prediction of the lid motion.

Simulating PCL separation is performed in two stages. Initially an air flow over spacecraft is defined (Fig. 3) [2]. After getting convergent solution the problem of separation of PCL is solved (Fig. 4, 5). During simulating PCL separation is taken into account pressure in parachute container and impulse of squib, getting first impulse to lid to shoot it. The goal of simulations is define the minimal impulse of a squibs to ensure an absence of collision between lid and spacecraft. The problem of removing collisions is complicated by the fact that at some spacecraft positions, lid can be in back-circulation zone (Fig. 4). As example, motion of PCL is shown in Fig. 5.



Fig. 1. General view of reusable spacecraft

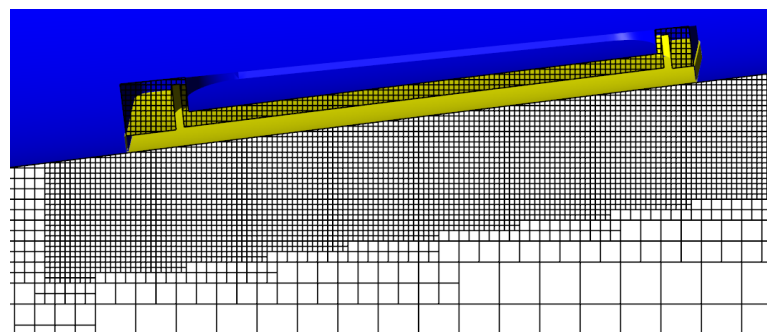
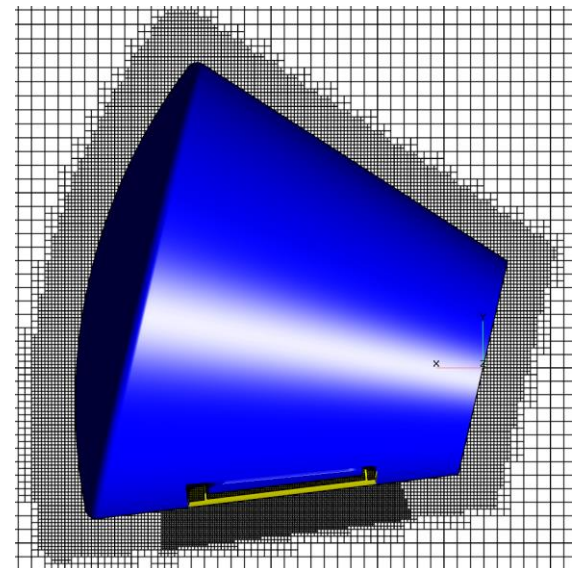
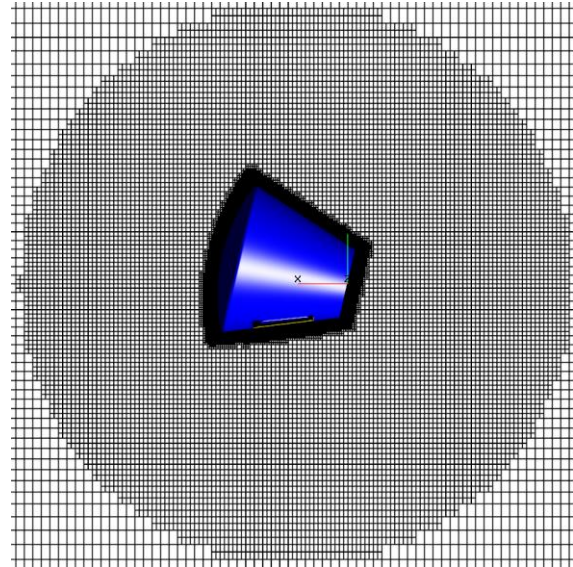

Fig. 2. Adapted mesh over spacecraft and lid

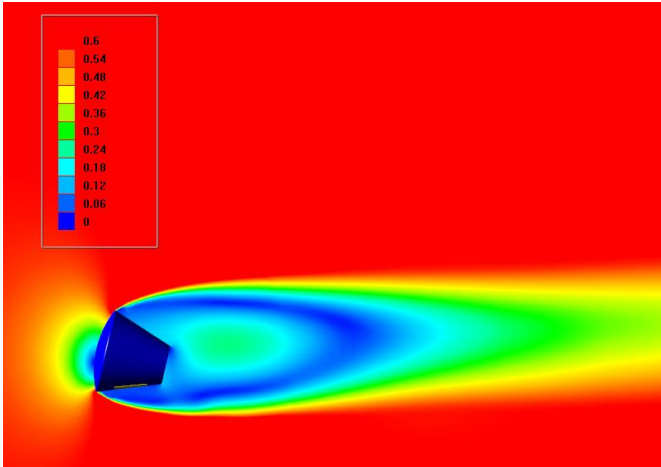

Fig 3. Mach number distribution over spacecraft before lid separation



Fig. 5. PCL positions in time at an angle of spacecraft attack 17°

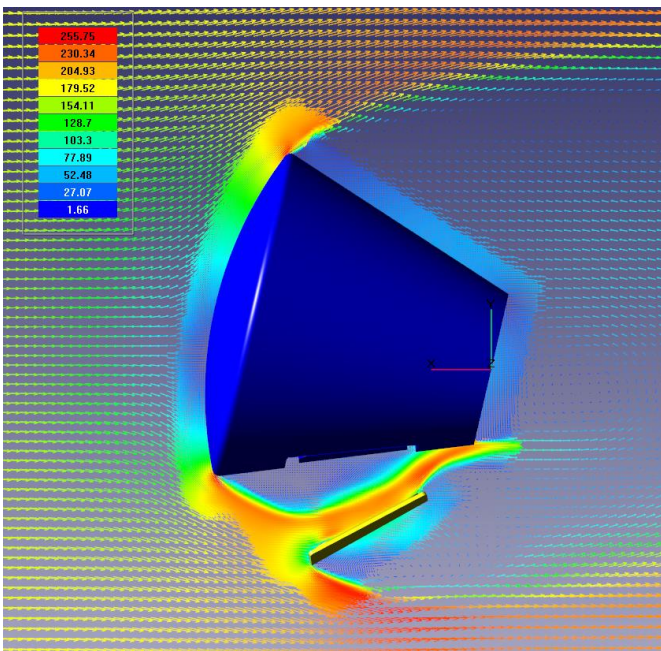

Fig. 4. Velocity distribution after lid separation

2 Shock-wave interaction on the spacecraft at turning on emergency rescue system (ERS).

Emergency rescue system (ERS) may trigger at rocket launch or at flight. Shock waves is formed in the ERS nozzles just after the start of propulsion systems. The shock waves interact with a surface of the spacecraft located below the ERS (Fig. 6). These shock waves provide force interaction on spacecraft structure.

A goal of this investigation is numerical simulation of unsteady gas dynamics and structure interactions on spacecraft at trigger of main propulsion system of ERS and propulsion system of emergency separation (ES ERS). The investigation is done for conditions at rocket start (Mach number = 0) and at rocket flight (Mach number = 1.5).

Pressure distribution and density distribution are shown in Fig. 7 and 8 during ERS operation at different conditions. In Fig. 7 is shown triggering ERS system at start (Mach number = 0), in Fig. 8 corresponds to flight of the rocket

at $M=1.5$. One can see that at flight conditions the supersonic jet from ERS nozzles interacts with oblique shocks formed on ERS structure because of rocket motion. Investigations shows that influence of shock waves after ERS start is acceptable from a point of view of maximum load on spacecraft structure.

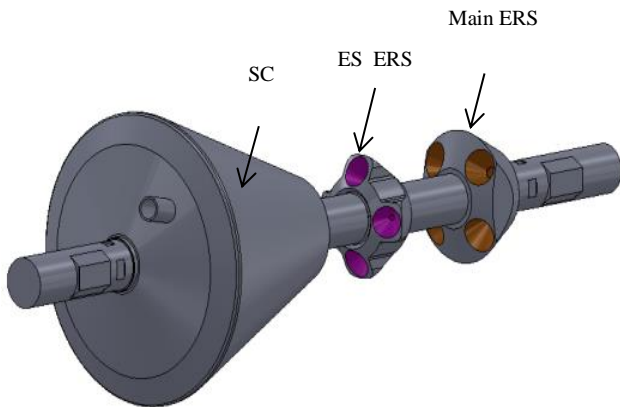

Fig. 6. General view of the spacecraft (SC) with ERS

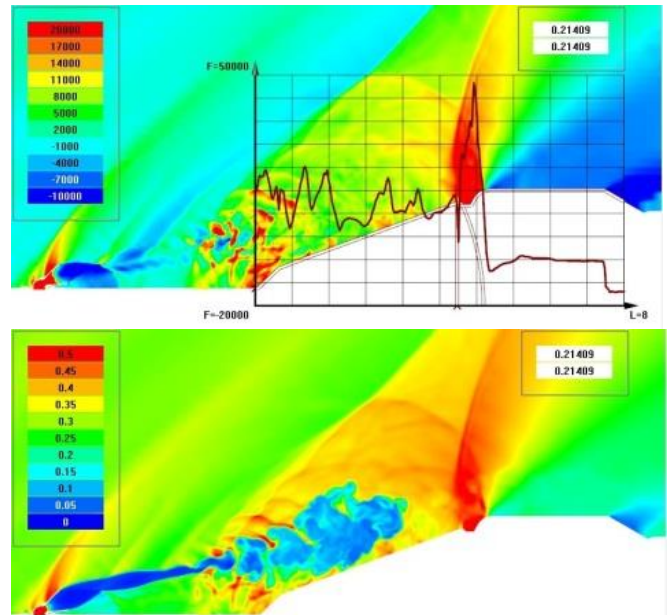

Fig. 8. Pressure distribution and density in plane of main ERS nozzle at $Mach=1.5$

3. Conclusion

RSC Energia has many years of successful experience of using experimental and engineering methods. Today, however, it becomes evident that using numerical simulation methods allows not only to save resources reducing number of costly experiments, but also achieves highly accurate and reliable results simulating processes that before could only be predicted using rough engineering methods.

References

- [1] Aksenov A., Dyadkin A., Pokhilko V. - Overcoming of barrier between CAD and CFD by modified finite volume method. *Proc. 1998 ASME Pressure Vessels and Piping Division Conf.* San Diego. ASME PVP. 1998. Vol. 377-1.
- [2] Дядькин А.А., Михайлова М.К., Сухоруков В.П., Щеляев А.Е. Математическое моделирование обтекания возвращаемого аппарата с работающей посадочной двигательной установкой. *Труды международной научно-практической конференции «Инженерные системы – 2011»*, Москва, 2011 г. – Том I. М.: РУДН, 2011 – 164 с.

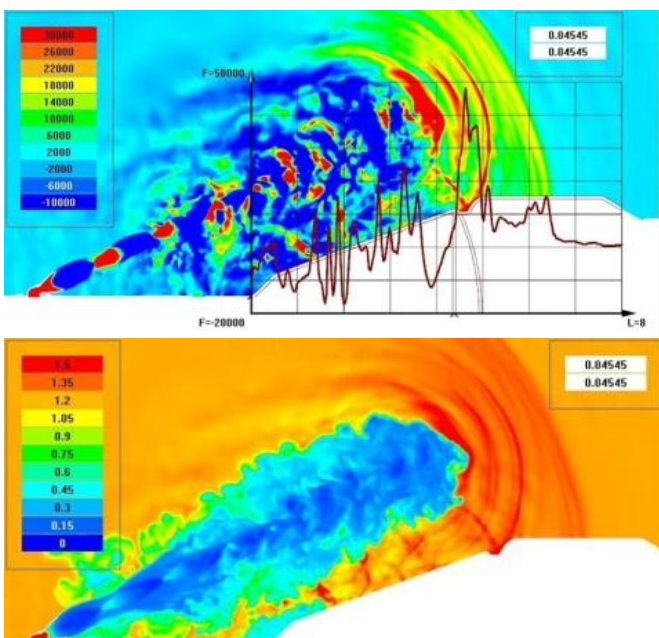

Fig. 7. Pressure distribution and density in plane of main ERS nozzle at $Mach = 0$

Contact Author Email Address

mailto:andrey@tesis.com.ru

Copyright Statement

The authors confirm that they, and/or their company or organization, hold copyright on all of the original material included in this paper. The authors also confirm that they have obtained permission, from the copyright holder of any third party material included in this paper, to publish it as part of their paper. The authors confirm that they give permission, or have obtained permission from the copyright holder of this paper, for the publication and distribution of this paper as part of the ICAS 2014 proceedings or as individual off-prints from the proceedings.